

Scan



# ST15 FX

10-16 ton machines

The ST15 FX is a robust tiltrotator designed for excavators of 10-16 tons. Improved hydraulics include a pressure relief valve directly on the motor, load holding valves on the cylinders, and a larger hydraulic distribution block for improved efficiency.

Available now with a high flow swivel, optimized for use with attachments requiring up to 200l/min of flow.

An innovative electric swivel can be added for further flexibility, enabling the transmission of sensor or CAN signals. Equipped with a new built-in encoder, the tiltrotator can be integrated with machine guidance or control systems, enabling more efficient and precise operation.

\* Read more on [smpparts.com](http://smpparts.com)

## SPECIFICATIONS

- Available with S45 Safelock, S50-70 Hardlock or FC45-70 Open-S couplers. Other quick coupler systems available on demand
- Up to 45 degrees of tilting
- Endless rotation
- Rotation sensor included on MACS control systems
- Central lubrication as standard
- Load holding valves on cylinders, for maximum safety
- Optional telescopic cylinders, reducing the total width
- Optional gripper, with exceptionally wide opening

## CONTROL SYSTEM

Available with SVAB's MACS proportional control system, MIC4.0 or 4-hose solutions. Other systems available on request.

## ELECTRICAL SYSTEM

For 24V systems.

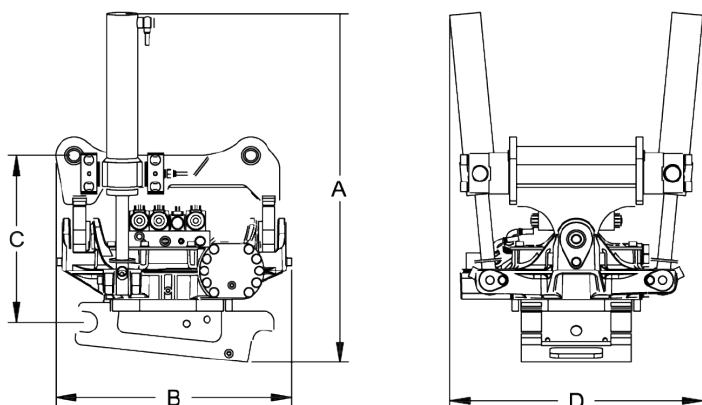

## SPECIFICATIONS

Typ	ST15 FX
Dimension A (mm)*	905
Dimension B (mm)*	726
Dimension C (mm)*	547
Dimension D (mm)*	665
Tilt angle max (°)	45
Weight from (kg)	415
Max breakout force (kNm)	110
Flow extra outlet (l/min)	60-65
High flow NG10 (l/min)	120
High flow "bypass" (l/min)	200
Typ	Grip
Weight (kg)	83/117/122 (S45-50/S60/S70)
Opening width (mm)	650/900 (S45-50/S60-70)

Dimensions, weights and tilt angle may vary depending on the configuration.