

Scan



ST18 FX

14-18 ton machines

The ST18 FX adds flexibility and efficiency to excavators of 14-18 tons. Improved hydraulics include a pressure relief valve directly on the motor, load holding valves on the cylinders, and a single hydraulic distribution block for improved efficiency.

Available now with a high flow swivel, optimized for use with attachments requiring up to 200l/min of flow. An innovative electric swivel can be added for further flexibility, enabling the transmission of sensor or CAN signals. Equipped with a new built-in encoder, the tiltrotator can be integrated with machine guidance or control systems, enabling more efficient and precise operation.

* Read more on smpparts.com

FEATURES

- Available with S60-70 Hardlock or FC60-70 Open-S couplers. Other quick coupler systems available on demand
- Up to 45 degrees of tilting
- Endless rotation
- Rotation sensor included on MACS control systems
- Central lubrication as standard
- Load holding valves on cylinders, for maximum safety
- Optional telescopic cylinders, reducing the total width
- Optional gripper, with exceptionally wide opening

CONTROL SYSTEM

Available with SVAB's MACS proportional control system, MIC4.0 or 4-hose solutions. Other systems available on request.

ELECTRICAL SYSTEM

For 24V systems.

SPECIFICATIONS

Specifications	ST18 FX
Tilt angle max (°)	45
Weight from (kg)	553
Max breakout force kN (ISO)	130
Flow extra outlet (l/min)	60-65
High flow NG10 (l/min)	120
High flow "bypass" (l/min)	200

Specifications	Grip
Weight (kg)	115/139 (S60/70)
Opening width (mm)	896/939

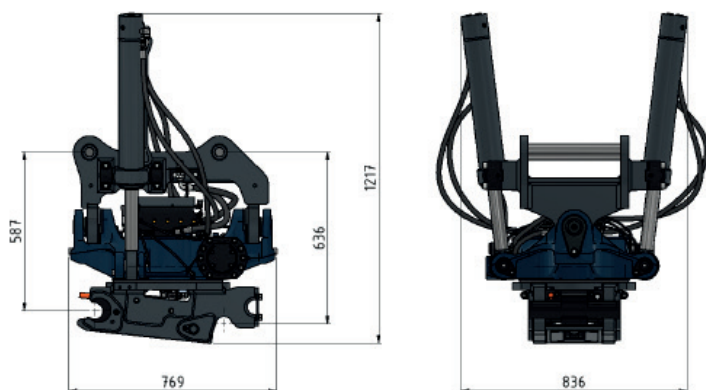

Dimensions for ST18 with S60 Hardlock

Dimensions, weights and tilt angle may vary depending on the configuration.