

Scan



ST10 FX

6-10 ton machines

The ST10 FX, suitable for carriers of 6-10 tons, adds incredible flexibility to any midsize excavator. With its endless rotation, 45° of tilting and optional gripper, the tiltrotator enables operators to tackle more complex jobs, without having to reposition the excavator – saving time, fuel and money. The new hydraulic distribution block has been optimized to reduce energy consumption.

Equipped with a new built-in encoder, the tiltrotator can be integrated with machine guidance or control systems, enabling more efficient and precise operation. The tiltrotator can be mounted on the excavator directly or on a quick coupler.

* Read more on smpparts.com

FEATURES

- Available with S45, S50 Hardlock or FC45 Open-S couplers. Other quick coupler systems available on demand
- Up to 45 degrees of tilting
- Endless rotation
- Rotation sensor included on MACS control systems
- Central lubrication as standard
- Load holding valves on cylinders, for maximum safety
- Optional telescopic cylinders, reducing the total width
- Optional gripper, with exceptionally wide opening

CONTROL SYSTEM

Available with SVAB's MACS proportional control system, MIC4.0 or 4-hose solutions. Other systems available on request.

ELECTRICAL SYSTEM

For 12V or 24V systems.

SPECIFICATIONS

| Specifications | ST10 FX |
|-----------------------------|---------|
| Tilt angle max (°) | 45 |
| Weight from (kg) | 310 |
| Max breakout force kN (ISO) | 70 |
| Flow extra outlet (l/min) | 60-65 |
| Specifications | Grip |
| Weight (kg) | 77 |
| Opening width (mm) | 738 |

Dimensions, weights and tilt angle may vary depending on the configuration.

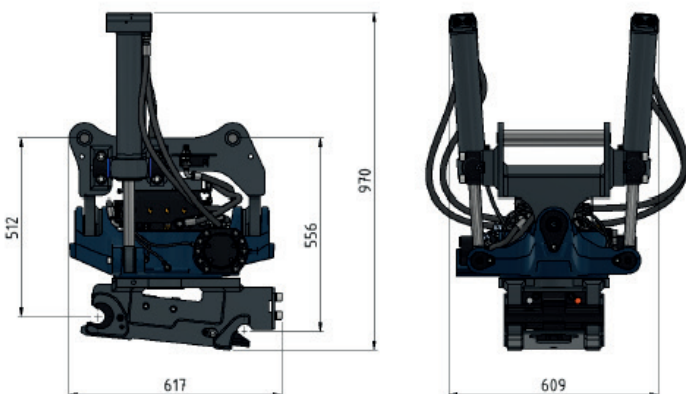

Dimensions for ST10 with S45 Hardlock