

Scan



ST6 FX

3-6 ton machines

The ST6 FX is small but powerful, suitable for excavators weighing between 3 and 6 tons. The SMP Tiltrotator improves the excavator's capabilities by making it more flexible and efficient.

High-precision work can be achieved without having to reposition the excavator. The tiltrotator's 360° rotation and 45° tilting capabilities allow for a wide range of tasks from a single position. The tiltrotator can be mounted on the excavator directly or on a quick coupler.

Equipped with a new built-in encoder, the tiltrotator can be integrated with machine guidance or control systems, enabling more efficient and precise operation.

* Read more on smpparts.com

FEATURES

- Available with S40 Safelock, S45-50 Hardlock or FC45 Open-S couplers. Other quick coupler systems available on demand
- Up to 45 degrees of tilting
- Endless rotation
- Rotation sensor included on MACS control systems
- Central lubrication as standard
- Load holding valves on cylinders, for maximum safety
- Optional gripper, with exceptionally wide opening

CONTROL SYSTEM

Available with SVAB's MACS proportional control system, MIC4.0 or 4-hose solutions. Other systems available on request.

ELECTRICAL SYSTEM

For 12V systems.

SPECIFICATIONS

Specifications	ST6 FX
Tilt angle max (°)	45
Weight from (kg)	160
Max breakout force kN (ISO)	50
Flow extra outlet (l/min)	60-65
Specifications	Grip
Weight (kg)	42/77 (S40/S45-50)
Opening width (mm)	469/738 (S40/S45-50)

Dimensions, weights and tilt angle may vary depending on the configuration.

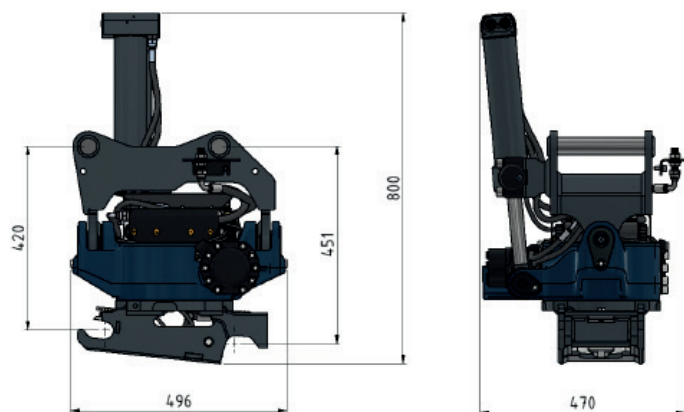

Dimensions for ST6 with S40 Safelock